

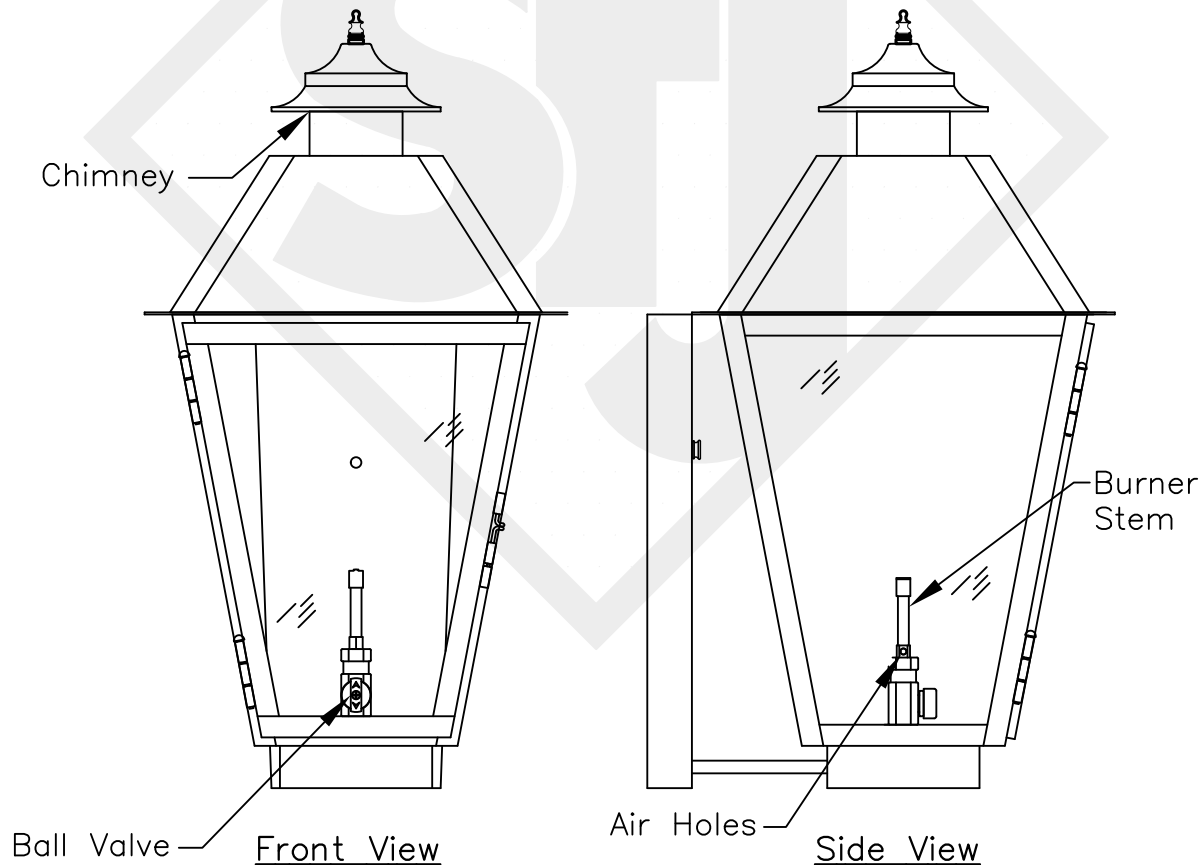

GENERAL GAS LANTERN MAINTENANCE

PROPANE GAS

Follow these instructions to maintain proper working order for your Gas Lanterns. Maintaining your Gas Lanterns will keep them working correctly for a long time. These processes are suggested 2–4 times a year, or as needed.

- Make sure the gas is turned off to the lantern and it has at least 10 minutes to cool off
- The burner stem has two small air holes at the base that are at the base that are used for mixing propane with oxygen. Use a can of compressed air and blow into the holes, freeing up any debris that would be blocking the gas flow. Spiders are attracted to propane and have been known to crawl inside the air holes and spin webs (It's recommended to spray around your lanterns for spiders)
- Make sure the chimney and bottom vent holes are free and clear of debris



General Gas Lantern Maintenance	
 St. James LIGHTING	
SCALE: N.T.S.	DRAFT: B. Vial
FILE: INSTALL	APP'D: J. Ragan
JOB: X	DATE: 11/1/17